

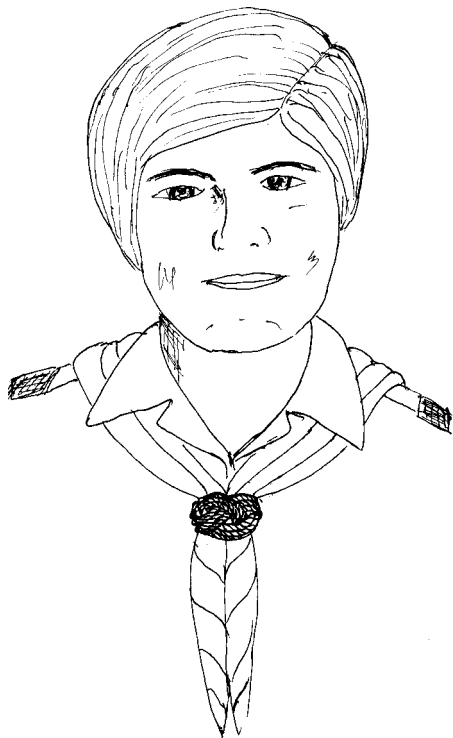

TURK'S HEAD:

Description ---- Three strand braid worked in a continuous circle.

Use ---- (1) As a decorative knot around a staff or railing. (2) Worked tight around a checked or cracked tool handle or canoe paddle to reinforce them. (3) As a neckerchief slide or wogal.

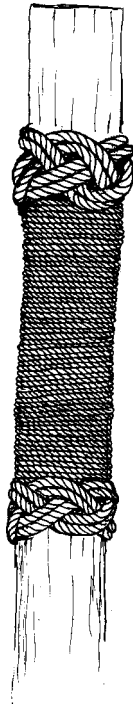

Comments ---- The form of Turks head shown here is a five crown Turk's head, this is only one of a group of knots that go by the name Turk's heads.

The crown number is determined by counting the number of bights at the edge of the knot. To make a larger loop, increase the size of the wraps made in steps 1 - 4 and then, at step 7 use three strand braiding to increase the number of crowns. The number of crowns can be increased by increments of three; so that the number of crowns in a larger loop can be 8, 11, 14, etc..

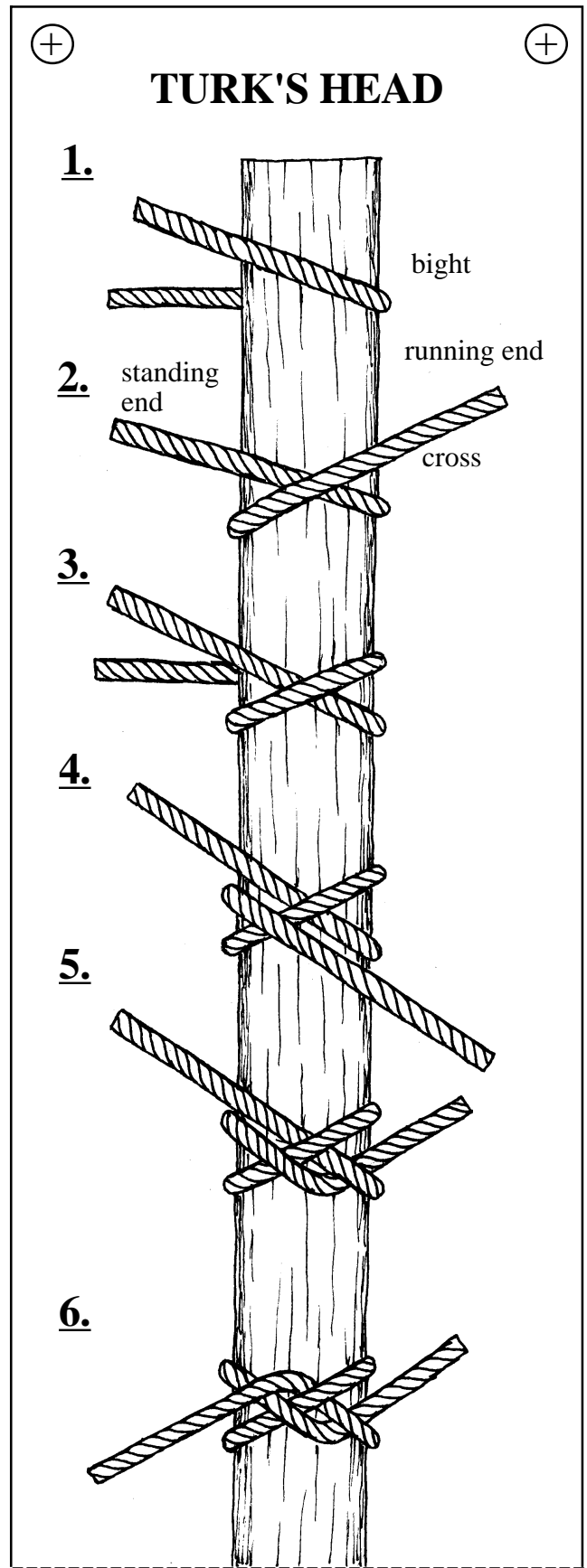

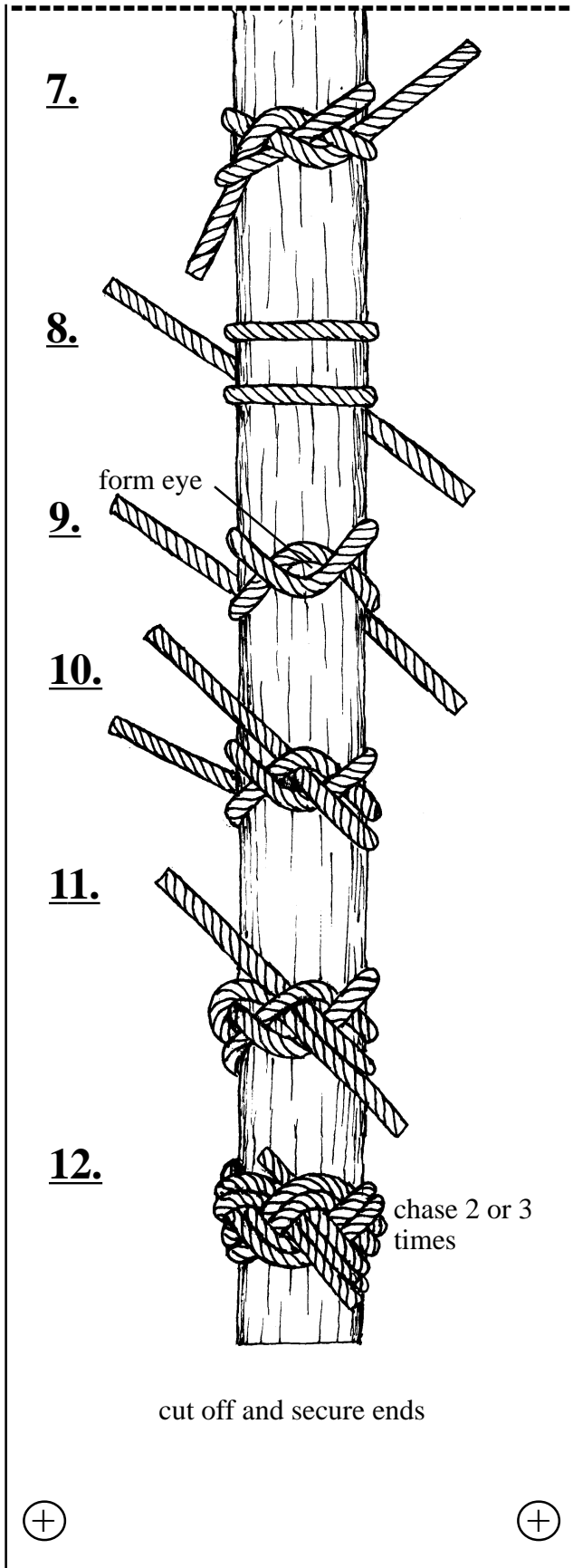

The size of the finished Turk's Head depends on the size of the rope used and the number of times the strand is chased.

Other Names ---- Three lead by five bight Turk's head, ordinary Turk's head.

Narration ----- (For Turk's head knotboard.)

(1) Start at the center of the line, by taking a bight around an object (the fingers of the left hand work well) (2) Complete the round turn and cross the running end over the standing end. (3) Take a second bight around the object so that the running end is between the standing end and the first wrap. (4) Lay the running end across the first wrap then (5) tuck the running end under the standing end. (6) lay the standing end across the second wrap and (7) tuck it under the first wrap. (8) rotate the knot around the object so that you are looking at the opposite side. (9) Cross the second wrap over the first wrap. (10) Reeve the standing end through the eye formed between the two wraps. (11) Reeve the running end through the eye between the two wraps so that the ends are in opposite directions. (12) Chase, follow, the strand of the knot two or three times. Cut off and secure the ends.

[NOTE] To determine the length of line to use, wrap the line around the object four times for a single strand knot. Add three and one half wraps for each time you intend to chase the original strand.